

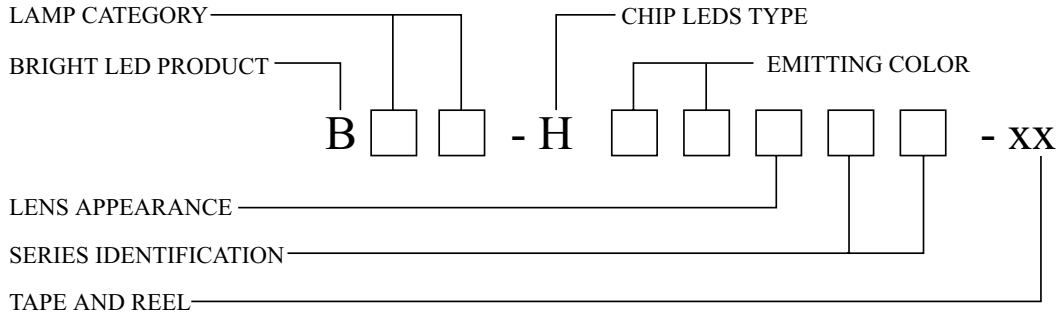

TAPE AND REEL SURFACE MOUNT CHIP LED LAMPS

SELECTION GUIDE (PART NO. SYSTEM)

- INFRARED EMITTING DIODES
- PHOTOTRANSISTORS
- PHOTODIODES



LAMP CATEGORY :

IR : Infrared Emitting Diodes
 PT : Phototransistors
 PD : Photodiodes

EMITTING COLOR :

Lx : GaAs/ GaAs940nm
 Nx : GaAlAs880nm
 Px : Silicon Phototransistors
 Mx : GaAlAs/GaAs 940nm
 Ox : GaAlAs/GaAlAs 850nm
 Qx : Silicon Photodiodes

TYPICAL ELECTIEICAL-OPTICAL CHARACTERISTICS CURVES

Infrared Emitting Diodes Series :

